

# Freewheel Clutches

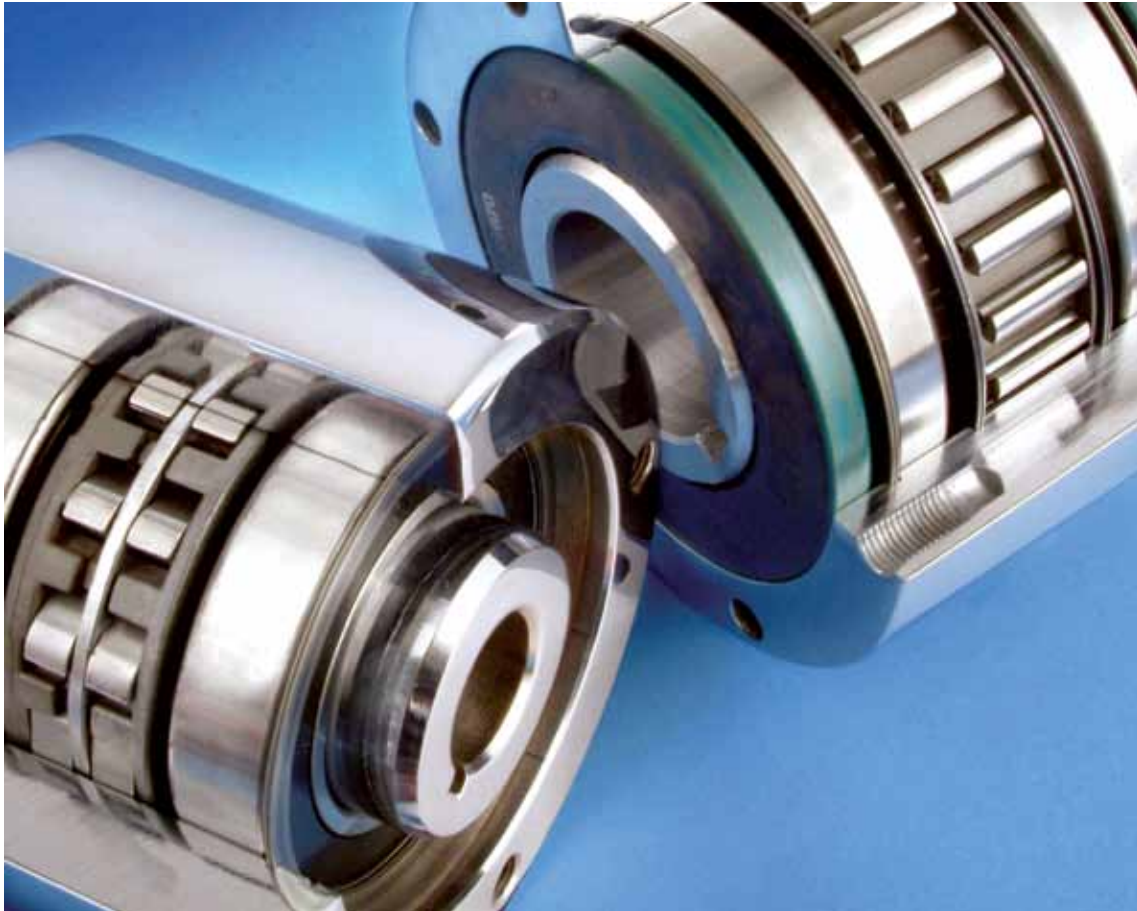

85

RINGSPANN® Registered Trade Mark of RINGSPANN GmbH, Bad Homburg



# Freewheel Clutches

## Introduction

RINGSPANN GmbH has operated for over 60 years, specializing in industrial freewheel clutch technology. **RINGSPANN CORPORATION**, as an exclusive distributor and licensee, manufactures and assembles sprag and roller clutches for the North American market. Superior German engineering and American ingenuity bring you a winning combination of quality products and delivery above industry standards. Products contained within this catalog represent **RINGSPANN CORPORATION** standard freewheel clutches. **RINGSPANN** can readily design new or modify existing products to suit your application.

**“RINGSPANN CORPORATION for all of your Freewheel Clutch needs.”**

## The RINGSPANN Service Advantage

- **RINGSPANN** Freewheel Clutches — your sole source in North America
- Outstanding service and delivery through improved inventory
- Detailed application support backed by over 60 years of experience
- Direct sales and service from the manufacturer

## The RINGSPANN Design Advantage

- Maximum torque capacity in a minimum space
- Springs on every sprag to provide extra security against failures
- Patented sprag profiles offer maximum life for each application
- **RINGSPANN** will modify existing product to meet your requirements

## Table of Contents

Function and Applications .....	1
Model FRS .....	2
Model FRZ .....	2
Model FRX .....	3
FR Series Dimensional Data .....	4
FR Series Selection Procedure .....	5
FR Series Options and Lubrication choices .....	6
How to Order .....	6
FR Series Accessories .....	7
Interchange Chart .....	8
FRH Series Low-Speed Backstops .....	9
ZZ & ZZ P Series .....	10
ZZ PP, ZZ 2RS & ZZ P2RS .....	11
CA Series Clutch Coupling Packages .....	12
RC & RCD Series .....	13

Issue 3/09-subject to technical changes



## Function and Applications

**FREEWHEEL CLUTCHES** are machine elements with the following characteristics:

### DRIVES IN ONE DIRECTION

The sprags lock the inner race to the outer race to drive and transmit torque.

### SLIPS IN THE OTHER DIRECTION

The sprags do not lock but slip and allow the inner or outer race to “freewheel”. No torque is transmitted.

The Freewheeling Function allows for:

- INDEXING
- OVERRUNNING
- BACKSTOPPING

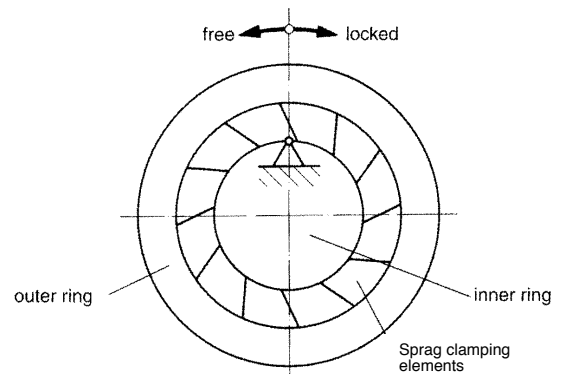

### Indexing

#### Function

RINGSPANN Freewheels, as indexing clutches, allow for a unidirectional, intermittent motion when a reciprocating motion is applied to a driving race.

#### Advantages

- Noiseless operation
- Fine setting of the feed path
- No backlash

#### Applications

- Printing machines
- Wire forming machines
- Forging presses
- High voltage current controls
- Packaging machines
- Paper converting
- Agriculture machines
- Wood processing



### OVERRUNNING

#### Function

RINGSPANN Freewheels, as overrunning clutches, provide for the automatic separation between the driver and driven equipment when the direction of force is changed.

#### Advantages

- Completely automatic
- Smooth transmission of torque

#### Applications

- Dual drives
- Starter & creep drives
- Planetary gears
- Ventilators and fans
- Rollout tables
- Rolling mills
- Continuous heating furnaces
- Conveyors



### BACKSTOPPING

#### Function

RINGSPANN Freewheels, as backstop clutches, provide for the prevention of rotation in the reverse direction for safety and functional reasons.

#### Advantages

- Long life
- Lower cost
- Completely automatic

#### Applications

- Inclined Conveyors and Elevators
- Pumps, blowers, and ventilators
- Grain Elevators
- Cranes and winches
- Torque converters
- Fans
- Gear drives
- Ski lifts



## Model FRS

The RINGSPANN Model FRS Clutch is designed as a general purpose freewheel to satisfy standard duty applications. These units are specially designed for overrunning, backstopping and indexing applications. The FRS Series is available with RINGSPANN RIDUVIT® Sprags, having undergone a process of diffusing chromium into the surface of the sprag, providing an extra hardened surface for superior wear resistance. All FRS Clutches are oil lubricated unless otherwise specified.



Chart A

SIZE	LUBRICATION	MAX BORE		Maximum Torque Capacities		Maximum Speeds (RPM)		
		Inches	mm	lb. ft.	Nm	Inner Race Overrunning	Outer Race Overrunning	Max. Driving Speed
FRSG-300	GREASE	0.750	19.050	295	400	3600	3600	3600
FRS-300	OIL					2500	2600	3600
FRSG-400	GREASE	0.875	22.225	340	461	3600	3600	3600
FRS-400	OIL					1900	2200	3600
FRSG-450	GREASE	1.125	28.575	450	610	3600	3600	3600
FRS-450	OIL					1900	2100	3600
FRSG-500	GREASE	1.312	33.338	1130	1532	3600	3600	3600
FRS-500	OIL					1400	1900	3600
FRSG-550	GREASE	1.625	41.275	1885	2556	3600	3600	3600
FRS-550	OIL					1175	1600	3600
FRSG-600	GREASE	2.000	50.800	2325	3153	3600	3600	3600
FRS-600	OIL					1100	1500	3600
FRSG-650	GREASE	2.500	63.500	3200	4340	3600	3600	3600
FRS-650	OIL					900	1250	3600
FRSG-700	GREASE	2.938	74.613	6800	9222	1800	1800	1800
FRS-700	OIL					790	1150	1800
FRSG-750	GREASE	3.438	87.313	10400	14105	1800	1800	1800
FRS-750	OIL					790	1150	1800
FRSG-775	GREASE	3.750	95.250	13000	17625	1800	1800	1800
FRS-775	OIL					750	1050	1800
FRSG-800	GREASE	4.500	114.300	14500	19666	1800	1800	1800
FRS-800	OIL					700	950	1800
FRSG-900	GREASE	5.437	138.100	20000	27115	1200	1200	1800
FRS-900	OIL					700	950	1800
FRSG-1000	GREASE	7.000	177.80	29400	39875	1200	1200	1200
FRS-1000	OIL					630	800	1200

## Model FRZ With Centrifugal Lift Off Z

Centrifugal Lift Off Z is designed for applications that require a low driving speed and a high speed, overrunning outer race. The FRZ features sprags that are designed to lift off the inner race during high speed overrunning of the outer race.

Chart B

SIZE	Lubrication	MAX BORE		MAXIMUM TORQUE CAPACITIES		Maximum Speeds (RPM)		
		Inches	mm	lb. ft.	Nm	Outer Race Overrunning	LIFT OFF	Max. Driving Speed
FRZ-400	OIL	0.875	22.225	340	461	2600	800	320
FRZ-500	OIL	1.312	33.338	1130	1532	2050	1400	560
FRZ-550	OIL	1.625	41.275	1885	2556	1800	1550	620
FRZ-600	OIL	2.000	50.800	2325	3153	1650	1450	580
FRZ-650	OIL	2.500	63.500	3200	4340	1400	1300	520
FRZ-700	OIL	2.938	74.613	6800	9222	1200	1160	465
FRZ-750	OIL	3.438	87.313	10400	14105	1200	1160	465
FRZ-775	OIL	3.750	95.250	13000	17625	1050	950	380
FRZ-800	OIL	4.500	114.300	14500	19666	975	880	350

### Lubrication:

1. Oil lubricated FRS and FRZ Freewheels are furnished with lipseals for positive protection, and with open bearings to provide for proper lubrication supply throughout the clutch.
2. Grease-packed lubrication is available in all FRS Clutches and should be used for general duty applications.



## Model FRX With Centrifugal Lift Off X

Centrifugal Lift Off X is designed for applications that require a low driving speed and a high speed overrunning inner race. The centrifugal force causes the sprag to lift off the outer race during overrunning. The lift off feature allows the freewheel to operate without friction and greatly reduces wear.

Figure B shows a RINGSPANN Freewheel in the overrunning mode. The sprags and the support ring are rotating with the inner ring. The centrifugal force has turned the sprag in a counter-clockwise position and located it against the support ring. During operation, each sprag moves into

this position individually. Once in position, there is no wear because of the clearance between the sprag and the outer race(a). When the speed of the inner race has dropped sufficiently to reduce the centrifugal force to that of the spring, the sprag returns to its location on the outer ring. (Fig. A)

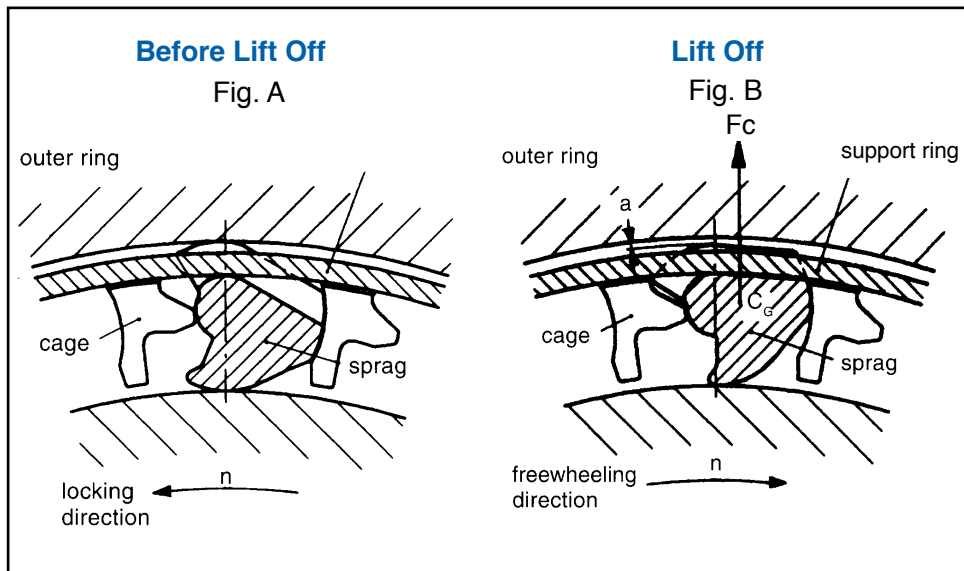

Chart C

SIZE	LUBRICATION	MAX BORE		MAXIMUM TORQUE CAPACITIES		MAXIMUM SPEEDS (RPM)		
		Inches	mm	lb. ft.	Nm	Inner Race Overrunning	Lift Off RPM	Max. Driving Speed
FRX-400	NONE	0.875	22.225	190	257	4000	860	340
FRX-500	NONE	1.312	33.338	580	786	4000	750	300
FRX-550	NONE	1.625	41.275	950	1288	4000	700	280
FRX-600	NONE	2.000	50.800	1275	1729	4000	670	265
FRX-650	NONE	2.500	63.500	2030	2753	4000	610	240
FRX-700	NONE	2.938	74.613	3000	4068	3600	350	140
FRX-750	NONE	3.438	87.313	5750	7798	2400	320	125
FRX-775	NONE	3.750	95.250	7800	10575	2100	320	125
FRX-800	NONE	4.500	114.300	11800	16004	1800	250	100
FRX-900	NONE	5.438	138.120	23600	32000	650	250	100

**Lubrication:**

- FRX Clutches are provided with sealed-for-life bearings. These clutches are maintenance free. Regreasing could lead to clutch failure.

# Series FRS, FRX, FRZ

## Dimensional Data

RINGSPANN CORPORATION manufactures a complete line of freewheel clutches. All clutches are held to the strictest of tolerances and conform to US machining standards.

Series FRS, FRX, and FRZ are designed and manufactured to provide quality freewheels that can be inventoried and made readily available to suit the customer's requirements.

RINGSPANN "Know How" enables RINGSPANN CORPORATION to provide the market with a clutch to suit your application.

The FR Series Freewheels are completely enclosed units that contain ball bearings and seals. Each of these units can be adapted to mate with pulleys, gears, sprockets, and torque arms.

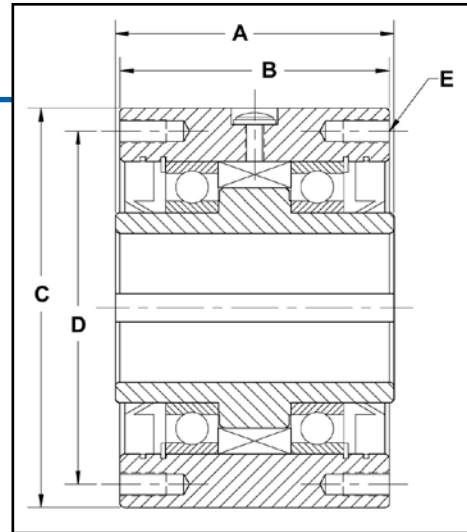

Chart E

DIMENSIONAL DATA								
FRS / FRX / FRZ			A	B	C	D	E	
SIZE	WEIGHT lbs./kg	MAX BORE IN./mm	LENGTH THROUGH BORE IN./mm	OUTER RACE LENGTH IN./mm	OUTSIDE DIAMETER IN./mm	BOLT CIRCLE IN./mm	STANDARD BORES AND KEYWAY SIZES** Inches	QTY. THREAD & SIZE OF BOLT HOLE IN./mm
300	3.5	0.750	2.500	2.380	3.000/2.998	2.625	0.500—1/8 X 1/16	(4)
	1.6	19.05	63.50	60.45	76.20/76.15	66.68	.625, .750—3/16 X 3/32	.25-28
400	6.0	0.875	2.750	2.687	3.500/3.498	2.875	0.500—1/8 X 1/16	(4) .312-24
	2.7	22.23	69.85	68.25	88.90/88.85	73.03	.625, .750, .875—3/16 X 3/32	
450	6.0	1.125	2.750	2.687	3.500/3.498	2.875	.750, .875—3/16 X 3/32	
	2.7	28.58	69.85	68.25	88.90/88.85	73.03	1.000, 1.125—1/4 X 1/8	
500	10.0	1.312	3.500	3.375	4.250/4.248	3.625	.875—3/16 X 3/32	(6) .312-24
	4.5	33.34	88.90	85.73	107.95/107.90	92.08	1.000, 1.125, 1.250—1/4 X 1/8 1.312—1/4 X 3/32	
550	12.0	1.625	3.250	3.125	4.750/4.748	4.250	1.25—1/4 X 1/8	
	5.4	41.28	82.55	79.38	120.65/120.60	107.95	1.312, 1.500—3/8 X 3/16 1.625—3/8 X 1/8	
600	19.0	2.000	3.750	3.625	5.375/5.373	4.750	1.25—1/4 X 1/8	(8) .375-24
	8.6	50.80	95.25	92.08	136.52/136.47	120.65	1.375, 1.438, 1.500—3/8 X 3/16 1.625, 1.688, 1.750—3/8 X 3/16 1.938, 2.000—3/8 X 1/8	
650	24.0	2.500	3.500	3.375	6.500/6.498	5.750	1.938, 2.000, 2.250—1/2 X 1/4	
	10.9	63.50	88.90	85.73	165.10/165.05	146.05	2.438, 2.500—5/8 X 1/8	
700	42.0	2.938	5.000	4.875	7.125/7.123	6.250	1.938, 2.000, 2.250—1/2 X 1/4 2.438, 2.500—5/8 X 5/16	(8) .375-24*
	19.0	74.61	127.00	123.83	180.98/180.92	158.75	2.750—5/8 X 7/32 2.938—5/8 X 1/8	
750	83.0	3.438	6.000	5.875	8.750/8.748	7.000	2.438, 2.500—5/8 X 5/16 2.938, 3.000—3/4 X 3/8	(8) .500-20*
	37.6	87.31	152.40	149.23	222.25/222.20	177.8	3.250—3/4 X 3/16 3.438—3/4 X 1/8	
775	96	3.75	6.000	5.875	9.750/9.748	8.500	2.750—5/8 X 5/16	(8) .500-20
	43.5	92.250	152.40	149.23	247.65/247.60	215.90	2.938, 3.000, 3.250—3/4 X 3/8 3.438, 3.500—7/8 X 5/16 3.750—7/8 X 1/4	
800	102.0	4.500	6.000	5.875	10.000/9.998	8.937	3.000, 3.250—3/4 X 3/8	
	46.2	114.30	152.40	149.23	254.00/253.95	227.00	3.438, 3.500, 3.750—7/8 X 7/16 3.937, 4.000—1 X 1/2 4.250—1 X 3/8 4.500—1 X 1/4	
900	156.0	5.438	6.375	6.250	12.000/11.998	9.75	4.00, 4.44, 4.50—1 X 1/2	(10) .625-18
	71.0	138.12	161.92	158.75	304.80/304.75	247.65	4.94, 5.00, 5.44—1 1/4 X 5/16	
1000	250.0	7.000	6.630	6.500	15.000/14.998	11.750	5.75, 5.94, 6.00—1 1/2 X 3/4	(12) .625-18
	113.0	177.80	168.30	165.10	381.00/380.95	298.45	6.75, 6.88, 7.00—1 3/4 X 7/16	

\* Six holes are equally spaced 60° apart with two additional holes located 30° from the six equally spaced holes and 180° apart.  
 • Centerline of the application of force on the outer ring should lie between the two ball bearings; this is particularly important for indexing applications.

\*\*Custom and metric bore available upon request.



## FR Series Clutch Selection Procedure

When selecting an FR Series Clutch based on torque, the following steps should be followed to ensure a correct selection.

1. Calculation of required torque to be transmitted through the clutch:
 
$$\text{Torque ( lb. ft.)} = \text{HP} \times 5250 \times \text{SERVICE FACTOR} \div \text{RPM}$$

$$\text{Torque ( Nm.)} = \text{kW} \times 9550 \times \text{SERVICE FACTOR} \div \text{RPM}$$
2. Apply the appropriate service factor based on the characteristics of the application. See chart D (below) for recommendations.
3. Establish required bore dimensions.
4. Determine the RPM of the overrunning race and the driving RPM.
  - Same direction rotation: overrunning speed is equal to the difference in the speed between the inner and outer race.
  - Opposite direction in rotation: the sum of the speeds.
5. Determine from the application the correct model of FR Freewheel.
  - FRS**
    - RINGSPANN FRS is recommended for general purpose applications, suitable for backstopping, overrunning, and indexing applications.
    - The drive and overrunning RPM should not exceed the maximum speed listed in Chart A, pg.2.
    - Consult factory for applications that require torque or RPM greater than those listed.
  - FRZ**
    - RINGSPANN FRZ Clutches are used in applications requiring high speed overrunning outer race and low driving speeds.
    - The drive RPM should not exceed the maximum speed listed in Chart B, pg.2.
    - Overrunning speed must be greater than or equal to the lift off speed.
    - Torque requirements should be within the allowable limits.
  - FRX**
    - For optimal results, the RINGSPANN FRX can be used for applications requiring low driving speeds and a high speed overrunning inner race, typically used as a backstop.
    - The drive RPM should not exceed the maximum speed listed in Chart C, pg.3.
    - Overrunning speed must be greater than or equal to the lift off speed.
    - Torque requirements should be within the allowable limits.
6. Determine method of lubrication. Many RINGSPANN clutches are available as oil lubricated, grease filled, or non-lubricated. See pg. 6 for FR Series options and pg.7 for accessories.

### Recommended Service Factors

Chart D

LOAD	TYPE OF EQUIPMENT	AC MOTOR	DC MOTOR	GAS ENGINE
Constant Torque Gradually applied loads	Centrifugal pumps, uniform-loaded conveyors, fan blowers, mixers and generators	1.25	1.25	1.75
Moderate Torque Light shock loads	Centrifugal pumps, cooling towers, boiler-feed pumps, machine tools, textile machinery, oscillating pumps	1.5	1.5	1.75
Medium Loads Medium shock loads	Rotary kilns, rotary and screw pumps, paper-converting machinery, punch presses, shears	1.5	1.75	Consult factory
Heavy Torques Heavy shock loads	Drilling rigs, rubber mixers, papermaking machinery, pulverizing mills, steel slitters	2.5	3	Consult factory

- Consult factory for diesel engines.

# FR Series

## Lubrication

### Grease lubricated

The FRS Series Clutch is available grease packed; these FRSG units are supplied with lipseals and open ball bearings.

### Oil lubricated

The FRS and FRZ Series Clutches are furnished with lipseals and open bearings to provide the best supply of lubrication to the clutch. Unless otherwise specified, oil lubrication will be supplied on all RINGSPANN CORPORATION FRS and FRZ Freewheels.

### Maintenance Free

The FRX units utilize sealed- for-life bearings and require no lubrication. FRX Freewheels are no maintenance clutches.

## Options

### Corrosion resistant

RINGSPANN Series FRX is available in a corrosion resistant (CR) design. Our special CR design incorporates the use of a full contact labyrinth seal to keep contaminants out; additionally we black oxide exposed surfaces to ensure long life.

### RIDUVIT®

RINGSPANN CORPORATION Series FRS Freewheels are available with RINGSPANN RIDUVIT. The RIDUVIT process diffuses chromium into the surface of the steel sprag. RIDUVIT Sprags provide maximum wear resistance for indexing, backstopping, and overrunning applications.

## How to Order

After determination of the clutch series and size, order specification should indicate type of lubrication, options, nominal bore, and keyway.

### Example #1

RINGSPANN CORPORATION Series FRX, size 700, complete with torque arm. Clutch bore 2 15/16" with a 5/8" X 5/16" keyway. Clutch to be maintenance free with sealed-for-life bearings.

#### Selection

**FRX-700-2.9375-.625"  
X .312"**

#### Selection

**FRX-700 Torque Arm**

### Example #2

RINGSPANN CORPORATION Series FRS, size 500, grease lubricated. Clutch bored to 1.000" with a 1/4" X 1/8" keyway. Sprags should be treated with the RINGSPANN RIDUVIT process for additional life.

#### Selection

**FRSG-500-RIDUVIT-  
1.000"-1/4" X 1/8"**

### Example #3

RINGSPANN CORPORATION Series FRS, size 500, oil lubricated. Clutch bored to 1.250" with a 1/4" X 1/8" keyway.

#### Selection

**FRS-500-1.250"-  
1/4" X 1/8"**



## FR Series-Accessories

### TA Torque Arms

TA torque arms are made specifically for use with the Ringspann FR\_ series freewheel clutches. The use of the TA torque arms facilitates the use of a standard freewheel clutch as a backstop.

Torque arms are available with any Ringspann FR\_ series size 300 through 1000. TA torque arms come predrilled and ready for installation.

#### Installation:

The torque arm must not be rigidly anchored. The torque arm must be restricted by either a non-threaded pin or an angle iron bracket. The torque arm must be free to move axially to prevent damage to the bearings in the clutch.

When a pin is used, the diameter of the pin must be 1/32 of an inch smaller than the pin hole (F) in the torque arm.

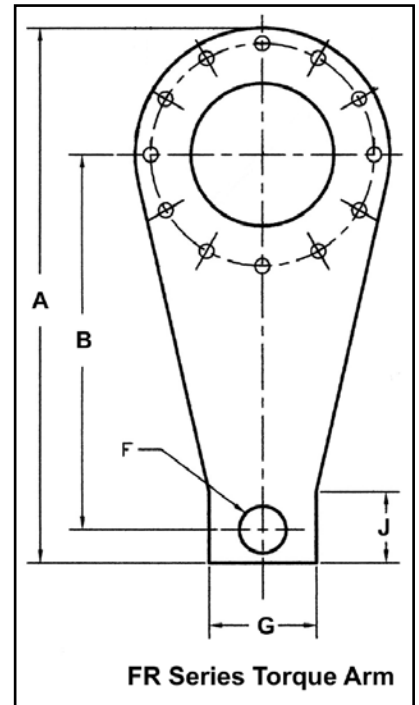

Torque Arm Dimensions (inches)						
Model	A	B	F	G	J	Thickness
TA 300	8.375	6.25	.53125	2	1	.375
TA 400/450	8.625	6.25	.53125	2	1	.375
TA 500	9	6.25	.53125	2	1.125	.375
TA 550	10.125	7	.78125	2.25	1.375	.375
TA 600	11.50	8	.78125	2.50	1.50	.375
TA 650	13.625	9.50	.78125	3	1.75	.375
TA 700	15	10.50	1.3125	3	2	.500
TA 750	18.375	12.875	1.28125	3.75	2.375	.500
TA 775	20	13.50	1.53125	4	2.50	.500
TA 800	21	14.625	1.53125	4	2.75	.500
TA 900	30.50	22.875	1.53125	4.75	3.375	.875
TA 1000	32	23	1.78125	5.25	3.375	.875

### End Covers

End covers are available to protect operating personnel from coming in contact with the rotating shaft for all FR Series clutches. Contact factory for availability.

### Labyrinth Seals

Labyrinth seals are offered to keep contaminants out of the clutch in harsh environments. Contact factory for availability.

# Interchange Chart

Chart F

RINGSPANN CORPORATION	Mariand Clutch	Mariand RINGSPANN	Formsprag	Morse®/EPT	Renold	GMN
FRS-300	RMS-12	N/A	HPI-300 or HSB-300	MG-300A or MI-300A	SO300	N/A
FRSG-300	RMS-12 FG	N/A	FSO-300	MG-300A or MO-300A	SO300	N/A
FRS-400	RMS-14	RMS-14	HPI-400 or HSB-400	MG-400A or MI-400A	SO400 or SX400	
FRSG-400	RMS-14 FG	RMS-14 FG	FSO-400	MG-400A or MO-400A	N/A	N/A
FRS-450	N/A	RMS-18	N/A	N/A	N/A	N/A
FRSG-450	N/A	RMS-18 FG	N/A	N/A	N/A	N/A
FRS-500	RMS-21	RMS-21	HPI-500 or HSB-500	MG-500A or MI-500A	SO500 or SX500	
FRSG-500	RMS-21 FG	RMS-21 FG	FSO-500	MG-500A or MO-500A	N/A	N/A
FRS-550	RMS-26	RMS-26	HPI-550 or HSB 550	N/A	N/A	N/A
FRSG-550	RMS-26 FG	RMS-26 FG	FSO-550	N/A	N/A	N/A
FRS-600	RMS-32	RMS-32	HPI-600 or HSB-600	MG-600A or MI-600A	SO600 or SX600	N/A
FRSG-600	RMS-32 FG	RMS-32 FG	FSO-600	MG-600A or MO-600A	N/A	N/A
FRS-650	RMS-40	RMS-40	HPI-650 or HSB-650	N/A	N/A	N/A
FRSG-650	RMS-40 FG	RMS-40 FG	FSO-650	N/A	N/A	N/A
FRS-700	RMS-47	RMS-47	HPI-700 or HSB-700	MG-700A or MI-700A	SO700 or SX700	N/A
FRSG-700	RMS-47 FG	RMS-47 FG	FSO-700 or HPO-700	MG-700A or MO-700A	N/A	
FRS-750	RMS-55	RMS-55	HPI-750 or FS-750 or HSB-750	MG-750 or MI-750 or MB-750	SO750 or SX750	N/A
FRSG-750	RMS-55 FG	RMS-55 FG	FSO-750 or HPO-750	MG-750 or MO-750 or MB-750	N/A	N/A
FRS-800	RMS-72	RMS-72	HPI-800 or FS-800 or HSB-800	MG-800 or MI-800 or MB-800	SO800 or SX800	N/A
FRSG-800	RMS-72 FG	RMS-72 FG	FSO-800 or HPO-800	MG-800 or MO-800 or MB-800	N/A	N/A
FRS-900	RMS-87	RMS-87	HPI-900	MI-900A	SX-900	N/A
FRS-1000	RMS-112	RMS-103	HPI-1027	MI-1000A	SX-1000	N/A
FRX-400	RMI-14	RMX-14	N/A	N/A	N/A	N/A
FRX-500	RMI-21	RMX-21	N/A	N/A	N/A	N/A
FRX-550	RMI-26	RMX-26	N/A	N/A	N/A	N/A
FRX-600	RMI-32	RMX-32	N/A	N/A	N/A	N/A
FRX-650	RMI-40	RMX-40	N/A	N/A	N/A	N/A
FRX-700	RMI-47	RMX-47	N/A	N/A	N/A	N/A
FRX-750	RMI-55	RMX-55	N/A	N/A	N/A	N/A
FRX-800	RMI-72	RMX-72	N/A	N/A	N/A	N/A
FRX-900	RMI-87	RMX-87	N/A	N/A	N/A	N/A
FRX-1000	RMI-112	RMX-112	N/A	N/A	N/A	N/A
ZZ-8	CSK-8	ZZ 8	CSK-8	N/A	N/A	N/A
ZZ-6201	CSK-12	ZZ-6201	CSK-12	N/A	N/A	N/A
ZZ-6202M	CSK-15	ZZ 6202M	CSK-15	N/A	N/A	N/A
ZZ-6203M	CSK-17	ZZ 6203M	CSK-17	KK-17	N/A	FK6203
ZZ-6204M	CSK-20	ZZ 6204M	CSK-20	KK-20	N/A	FK6204
ZZ-6205M	CSK-25	ZZ 6205M	CSK-25	KK-25	N/A	FK6205
ZZ-6206S	CSK-30	ZZ 6206S	CSK-30	KK-30	N/A	FK6206
ZZ-6206/25S	N/A	ZZ6206/25S	N/A	N/A	N/A	N/A
ZZ-6207M	CSK-35	ZZ 6207M	CSK-35	KK-35	N/A	N/A
ZZ-40	CSK-40	ZZ 40	CSK-40	N/A	N/A	N/A
FCN-8R	AS-8	FCN-8	AS-8	NSS-8	N/A	N/A
FCN-10R	AS-10	FCN-10	AS-10	NSS-10	N/A	N/A
FCN-12R	AS-12	FCN-12	AS-12	NSS-12	N/A	N/A
FCN-15R	AS-15	FCN-15	AS-15	NSS-15	N/A	N/A
FCN-20R	AS-20	FCN-20K	AS-20	NSS-20	N/A	N/A
FCN-25R	AS-25	FCN-25K	AS-25	NSS-25	N/A	N/A
FCN-30R	AS-30	FCN-30K	AS-30	NSS-30	N/A	N/A
FCN-35R	AS-35	FCN-35CF	AS-35	NSS-35	N/A	N/A
FCN-40R	AS-40	FCN-40CF	AS-40	NSS-40	N/A	N/A
FCN-45R	AS-45	FCN-45CF	AS-45	NSS-45	N/A	N/A
FCN-50R	AS-50	FCN-50CF	AS-50	NSS-50	N/A	N/A
FCN-60R	AS-60	FCN-60CF	AS-60	NSS-60	N/A	N/A
FCN-80R	AS-80	FCN-80	AS-80	N/A	N/A	N/A
RC-205		R205	FS 20-5	B205A		
RC-206		R206	FS 20-6	B206A		
RC-207		R207	FS 20-7	B207A		
RC-208		R208	FS 20-8	B208A		
RC-210		R210	FS 20-10	B210A		



## FRH Series Low-Speed Backstops

FRH Low-Speed Backstops are well suited for conveyor and other material handling applications. They are available with bores from 2.75 to 7.00 inches and torques from 10,000 to 45,000 lb.-ft.

These backstops are equipped with taconite seals and axial retention on the shaft. They easily adapt to suit many existing backstop applications.

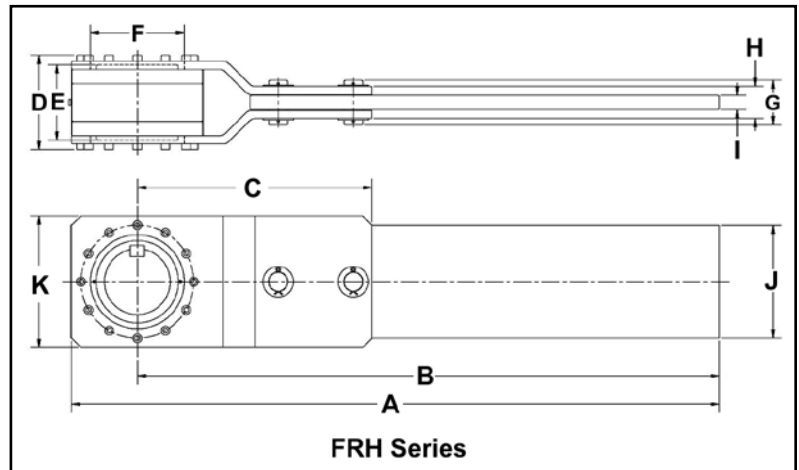

Dimensions (Inches)															
FRH Size	Torque (lb.-ft.)	Max Bore	Max Speed (RPM)	L Load (Lbs)	A	B	C	D	E	F	G	H	I	J	K
775	10,000	3.75	500	3160	42.875	38	20.375	9	7.5	6	4	2.625	1	8	9.75
800	13,000	4.50	400	4105	43.25	38	22.125	9.5	8	7	4	2.625	1	10	10.50
900	18,000	5.438	350	4500	54	48	22.75	9.375	7.625	8	4.5	3.125	1.5	10	12
1000	28,000	7.00	300	5420	69	62	25	10	8	10	4.75	3.375	1.5	12	14
1100	45,000	7.00	200	7500	79	72	29	12.5	10.5	10	4.75	3.375	1.5	12	14

## FRXG Series Clutches with #10, 20 and 60 Torque Arm Kits

Freewheel Clutches with #10, 20 and 60 Torque Arm Kits are available to easily adapt to many of the high-speed external backstops currently in use. They are dimensionally interchangeable and offer greater torque capacity. They are dimensionally interchangeable and offer greater torque capacity. The sprags in the "X lift-off" series centrifugally disengage from the outer race while overrunning. This results in **No Contact** or **Wear** of the sprags or outer race during operation. Also, **No Maintenance** is required for these units because they come sealed with Laminar-style labyrinth seals and are lubricated for life from the factory.

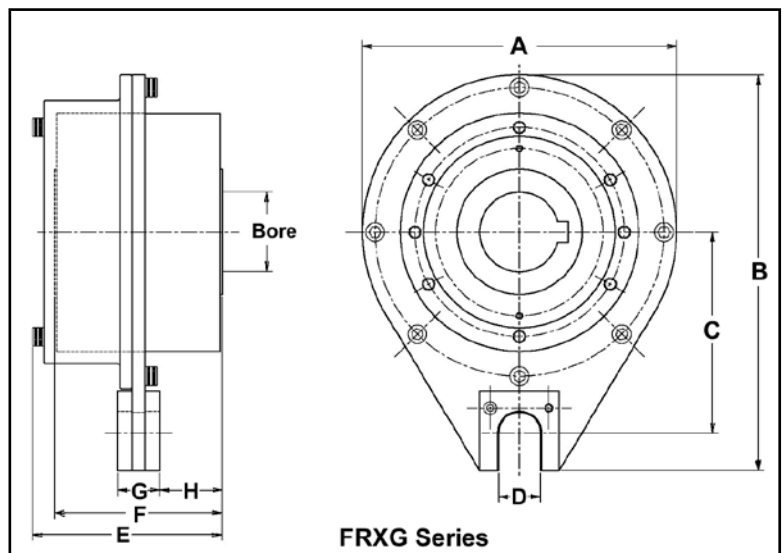

Dimensions (Inches)									
TORQUE ARM SERIES	Freewheel Clutch	A	B	C	D	E	F	G	H
10	FRX 550	6.75	8.313	4.00	.813	3.813	3.25	1.00	1.125
20	FRXG 700	9.375	11.813	6.00	1.25	5.688	5.00	1.25	1.875
60	FRXG 775	13.00	15.825	7.76	1.875	6.938	6.00	1.50	2.25

# Series ZZ With ball bearing properties

## Features

ZZ Internal Freewheels...are sprag freewheels with bearing support and ball bearing properties. The freewheels are supplied grease filled for normal operating conditions.

These freewheels are designed to be built into the customer's housing making a compact, space saving solution.

The ZZ Internal Freewheels... are used as:

- Backstops
- Overrunning Clutches
- Indexing Freewheels

The torque is transmitted through the inner and/or the outer ring by press fit or keyway connection. Bores up to 40mm are available with torques up to 240 Lb Ft.

The following series are available:

- ZZ = inner & outer press fit
- ZZ-P = inner keyway & outer press fit
- ZZ-PP = inner & outer keyway
- ZZ-2RS = inner & outer press fit with 2 rubber seals
- ZZ-P2RS = inner keyway & outer press fit with 2 rubber seals

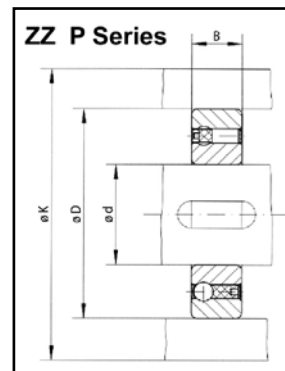
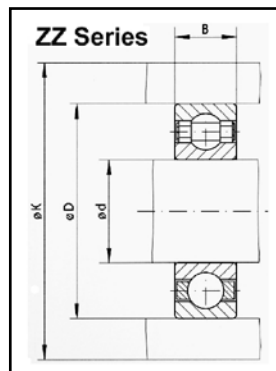

### Series ZZ

Model	d Bore		TORQUE lb. ft.	B		D		K		Load Capacity (lbs)	
	In.	mm		In.	mm	In.	mm	In.	mm	Dynamic	Static
ZZ-8	0.315	8	1.8	0.354	9	0.866	22	1.063	27	740	198
ZZ-6201	0.472	12	6.9	0.394	10	1.260	32	1.535	39	1370	620
ZZ-6202 M	0.591	15	19	0.433	11	1.378	35	1.654	42	1350	830
ZZ-6203 M	0.669	17	25	0.472	12	1.575	40	2.008	51	1650	1025
ZZ-6204 M	0.787	20	48	0.551	14	1.850	47	2.283	58	2250	1415
ZZ-6205 M	0.984	25	59	0.591	15	2.047	52	2.480	63	2500	1575
ZZ-6206 S	1.181	30	125	0.630	16	2.441	62	2.874	73	3400	2250
ZZ-6207	1.378	35	207	0.669	17	2.835	72	3.346	85	2835	1640
ZZ-40	1.575	40	240	0.866	22	3.150	80	3.701	94	3497	2755

Above torques are nominal and contain a safety factor of 2. Average number of indexes at 100% rated torque is 6,000,000.

### Series ZZ P

MODEL	d BORE		TORQUE lb. ft.	B		D		K		Load Capacity (lbs)	
	In.	mm		In.	mm	In.	mm	In.	mm	Dynamic	Static
ZZ 6202 P	0.591	15*	13	0.433	11	1.378	35	1.654	42	1665	765
ZZ 6203 P	0.669	17*	23	0.472	12	1.575	40	2.008	51	1780	1775
ZZ 6204 P	0.787	20*	37	0.551	14	1.850	47	2.283	58	2115	1010
ZZ 6205 P	0.984	25*	63	0.591	15	2.047	52	2.480	63	2410	1235
ZZ 6206 P	1.181	30*	102	0.630	16	2.441	62	2.874	73	2630	1460
ZZ 6206/25S	0.984	25	125	0.630	16	2.441	62	2.874	73	3400	2250
ZZ 6207 P	1.378	35*	129	0.669	17	2.835	72	3.346	85	2835	1640
ZZ 40 P	1.575	40	240	0.866	22	3.150	80	3.701	94	3485	2765

Keyway according to DIN 6885, page 1. The bores marked with \* have a keyway to DIN 6885, page 3. Keyway width tolerance: JS10. The torques listed are nominal torques and contain a safety factor of 2.



## Series ZZ With ball bearing properties

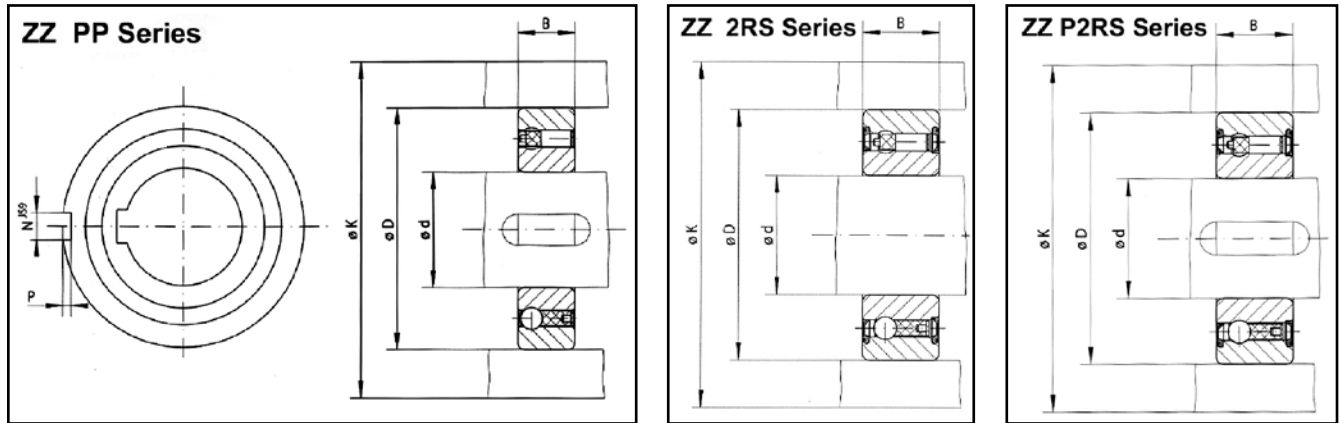

### Series ZZ PP

MODEL	d BORE		TORQUE lb. ft.	b mm	t mm	B		D		K		Load Capacity (lbs)	
	In.	mm				In.	mm	In.	mm	In.	mm	Dynamic	Static
ZZ 6202 PP	0.591	15*	13	2	0.6	0.433	11	1.378	35	1.654	42	1665	765
ZZ 6203 PP	0.669	17*	23	2	1.0	0.472	12	1.575	40	2.008	51	1780	1775
ZZ 6204 PP	0.787	20*	37	3	1.5	0.551	14	1.850	47	2.283	58	2115	1010
ZZ 6205 PP	0.984	25*	63	6	2.0	0.591	15	2.047	52	2.480	63	2410	1235
ZZ 6206 PP	1.181	30*	102	6	2.0	0.630	16	2.441	62	2.874	73	2630	1460
ZZ 6207 PP	1.378	35*	129	8	2.5	0.669	17	2.835	72	3.346	85	2835	1640
ZZ 40 PP	1.575	40	240	10	3.0	0.866	22	3.150	80	3.701	94	3485	2765

Keyway according to DIN 6885, page 1. The bores marked with \* have a keyway to DIN 6885, page 3. Keyway width tolerance: JS10. The torques listed are nominal torques and contain a safety factor of 2.

### Series ZZ 2RS

MODEL	d BORE		TORQUE lb. ft.	B		D		K		Load Capacity (lbs)	
	In.	mm		In.	mm	In.	mm	In.	mm	Dynamic	Static
ZZ 12 2RS	0.472	12	6.9	0.551	14	1.260	32	1.535	39	1370	630
ZZ 15 2RS	0.591	15	13	0.630	16	1.378	35	1.654	42	1665	765
ZZ 17 2RS	0.669	17	23	0.669	17	1.575	40	2.008	51	1780	1775
ZZ 20 2RS	0.787	20	37	0.748	19	1.850	47	2.283	58	2115	1010
ZZ 25 2RS	0.984	25	63	0.787	20	2.047	52	2.480	63	2410	1235
ZZ 30 2RS	1.181	30	102	0.827	21	2.441	62	2.874	73	2630	1460
ZZ 35 2RS	1.378	35	129	0.866	22	2.835	72	3.346	85	2835	1640
ZZ 40 2RS	1.575	40	240	1.063	27	3.150	80	3.701	94	3485	2765

The torques listed are nominal torques and contain a safety factor of 2.

### Series ZZ P2RS

MODEL	d BORE		TORQUE lb. ft.	B		D		K		Load Capacity (lbs)	
	In.	mm		In.	mm	In.	mm	In.	mm	Dynamic	Static
ZZ 20 P2RS	0.787	20*	37	0.748	19	1.850	47	2.283	58	2115	1010
ZZ 25 P2RS	0.984	25*	63	0.787	20	2.047	52	2.480	63	2410	1235
ZZ 30 P2RS	1.181	30*	102	0.827	21	2.441	62	2.874	73	2630	1460

Keyway according to DIN 6885, page 3. Keyway width tolerance: JS10. The torques listed are nominal torques and contain a safety factor of 2.

## Series CA Clutch Coupling Packages

Clutch couplings are used in applications that require the coupling of two in-line shafts, such as between a reducer and a pinion stand. The clutch should always be mounted on the low temperature shaft in any application. The CA series clutch couplings allow for the removal of the clutch,

adapter and coupling without moving the connected equipment. The clutch bore, coupling bore and distance required between the shafts must be specified at time of order.

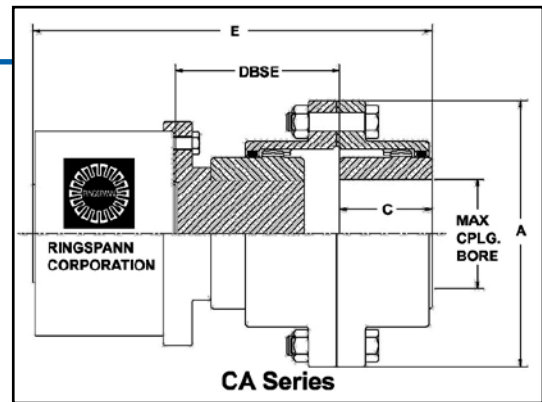

Package Model Number	Clutch Model	Coupling Model	Max. Coupling Bore (Inches)	Max. Clutch Bore (Inches)	A Major Diameter (Inches)	C Bore Length (Inches)	E Overall Length (Inches)	DBSE (Inches)
FR 300 CA10	300	F 1.0	1.75	.75	4.560	1.688	7.688	3.50
FR 400 CA12	400	F 1.0	1.75	.875	4.56	1.688	8.188	3.75
FR 500 CA15	500	F 1.5	2.313	1.313	6.00	1.938	9.625	4.188
FR 550 CA20	550	F 2.0	2.875	1.625	7.00	2.438	10.688	5.00
FR 600 CA20	600	F 2.0	2.875	2.00	7.00	2.438	10.50	4.313
FR 650 CA25	650	F 2.5	3.75	2.50	8.375	3.031	11.656	5.125
FR 700 CA30	700	F 3.0	4.375	2.938	9.438	3.594	15.469	6.875
FR 750 CA35	750	F 3.5	5.00	3.348	11.00	4.188	18.938	8.75
FR 775 CA40	775	F 4.0	5.875	3.75	12.50	4.75	20.25	9.50
FR 800 CA40	800	F 4.0	5.875	4.50	12.50	4.75	18.438	7.688
FR 900 CA45	900	F 4.5	6.50	5.438	13.625	5.313	20.813	9.125
FR 1000 CA50	1000	F 5.0	7.125	7.00	15.50	6.031	22.781	10.125

## Additional Style Clutch Coupling Packages

Other types of clutch coupling packages are available, such as close coupled, with disc couplings or with u-joint couplings. Consult factory for availability.

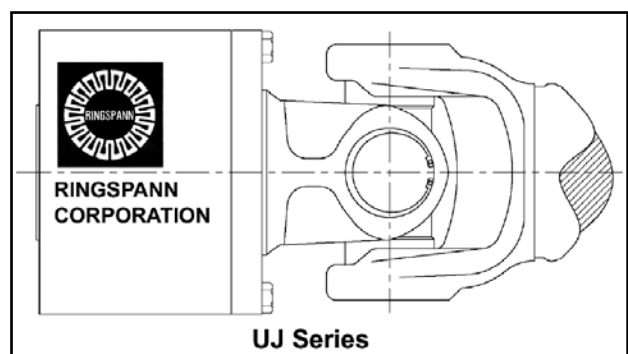
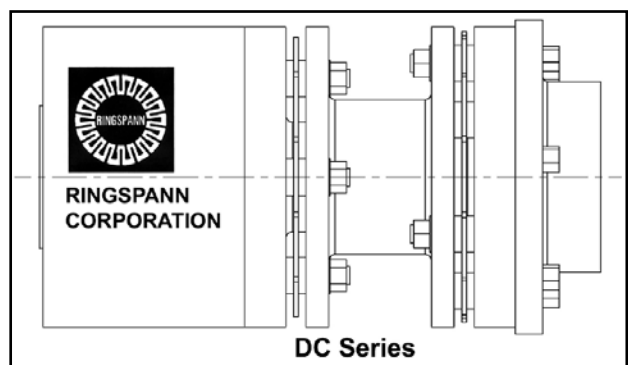
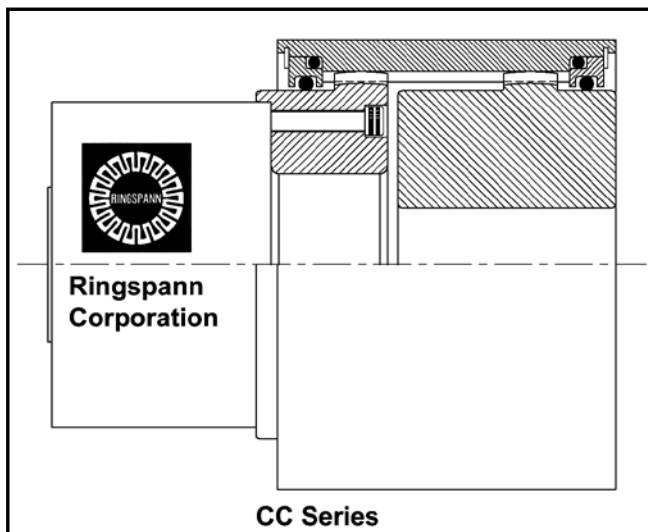



## Series RC Backstops

Series RC Clutches are shaft mounted with the same diameter as a 200 series ball bearing, but have no bearing characteristics.

All 200 Series Clutches require bearing support, a shaft hardened to HRC 58-62 with a .060" case depth after grinding to a 16 micro finish. In addition, eccentricity between the shaft and the housing bore should not exceed .002" T.I.R. with a taper on the shaft not to exceed .0002" per inch of shaft. The RC200 Series requires lubrication and may be either oil or grease lubricated. Lubrication containing molybdenum disulphide must not be used.

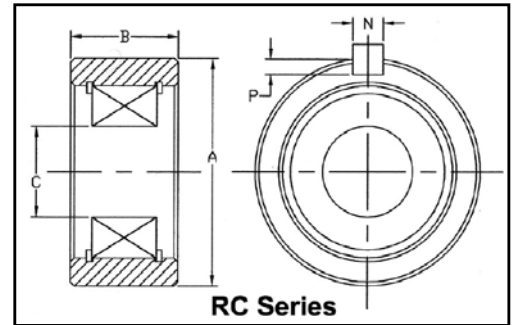

SIZE	Max. Torque lb.ft.	Housing Bore Diameter	Freewheel Diameter	B	C	Keyway N x P	Use with Bearing	Approx. Weight lbs.
		Inches	Inches	Inches	Inches	Inches		
RC-205	110	2.0482/2.0467	2.0463/2.0448	1	.926/.930	3/16" x 3/32"	205	¾
RC-206	195	2.4422/2.4407	2.4403/2.4388	1.125	1.289/1.290	¼" x 1/8"	206	1
RC-207	325	2.8360/2.8345	2.8341/2.8326	1.125	1.656/1.657	¼" x 1/8"	207	1 ¼
RC-208	450	3.1510/3.1495	3.1491/3.1476	1.25	1.840/1.841	3/8" x 3/16"	208	1 ¾
RC-210	620	3.5447/3.5432	3.5428/3.5413	1.25	2.208/2.209	3/8" x 3/16"	210	2

## Series RCD Backstops

Series RCD Backstops are a direct replacement for the Dodge backstops in TXT (and prior) series shaft mounted reducers. (see interchange chart at right.)

The RCD Backstops are equal dimensionally to the Dodge models and have equal or greater torque capabilities.



Ringspann Model	New Model TXT, TDT, TD Series	Old Model TXT Series	Backstop Part No.
RCD-3	TXT 325A, 315A & 309A	N/A	243106
RCD-4	TXT 425A, 415A & 409A	N/A	244106
RCD-5	TXT 525B, 515B & 509B TXT 525A, 515A & 509B TXT 525, 515 & 509	N/A N/A N/A	245154
RCD-6	TXT 625, 615 & 609 TDT 625 & 615 TD 625A & 615A TD 625 & 615 N/A	TXT 605 T 16 N/A N/A No. 16A	246092
RCD-7	TXT 725, 715 & 709 TDT 725 & 715 TD 725A & 715A TD 725 & 715 N/A	TXT 705 T 17 N/A N/A No. 17A	247260
RCD-8/9	TXT 825, 815, 926 & 915 TDT 825, 815, 926, 1125 & 1115 TD 825A & 815A TD 825, 815, 915, 1125 & 1115 No. 8 & No. 9	N/A N/A N/A N/A No. 18	249260
RCD-10/12	TXT 1024, 1015, 1225 & 1215 TDT 1024, 1015, 1225 & 1215 TD 1024, 1015, 1225 & 1215	TXT 805 T 18	250260
RCD-13	TDT 1325	TXT 905	272259

# RINGSPANN®

## Power Transmission

### Freewheels

#### Backstops

Automatic protection against reverse running of conveyor belts, elevators, pumps and fans.



Catalogue 88

#### Indexing Freewheels

For gradual feed of materials.

Catalogue 80



#### Overtopping Freewheels

Automatic engaging and disengaging of drives.

Catalogue 80



#### Housing Freewheels

Automatic engaging and disengaging for multi-motor drives for installations with continuous operation.

Catalogue 80.1



#### Freewheel Elements

Cage Freewheels, Sprag Sets and Freewheel Chains.

Catalogue 89



### Brakes

#### Industrial Disc Brakes

Spring Activated—Pneumatic Release.

Catalogue 46



#### Industrial Disc Brakes

Spring Activated—Hydraulic Release.

Catalogue 46



#### Industrial Disc Brakes

Spring Activated—Pneumatically Activated.

Catalogue 46



#### Industrial Disc Brakes

Brake Calipers—Hydraulically Activated.

Catalogue 46



#### Fall-Safe Clamping Units

For secure and precise positioning of piston rods.

Catalogue 32



### Torque and Force Limiters

#### Torque Limiter with Screw Face

Reliable overload protection for tough operating conditions.

Catalogue 45



#### Torque Limiter with Rollers

With double or single Roller. Through ratcheting or disengaging, also for 360° synchronous running.

Catalogue 45



#### Torque Limiter with Spherical Rollers

Reliable overload protection with maximum response accuracy. Also backlash free.

Catalogue 45



#### Torque Limiter with Friction Lining

RIMOSTAT Torque Limiter for constant torque, Belleville Spring Torque Limiter for simple release.

Catalogue 45



#### Force Limiter

Reliable axial overload protection in piston rods.

Catalogue 49



### Couplings

#### Flexible Couplings

Large, safe radial and angular misalignments. Minimum resiliency.

Catalogue 44



#### Clamping Coupling

For the automatic coupling of rolls. Fast, safe and free from slipping connection.



### Cables

Push/Pull Cables for controlling force and motion. With or without control heads



### Shaft Hub Connection

#### Cone Clamping Elements

For shaft-hub connections. High torques with small dimensions.

Catalogue 31



#### Three-part Shrink Discs

External clamping connection for the fastening of hollow shafts on solid shafts.

Catalogue 31



#### Two-part Shrink Discs

External clamping connection. Advantages: Simple, secure mounting even without torque wrench.

Catalogue 31.1



#### Star Discs

Ideal for shaft-hub-connection for frequent release.

Catalogue 30



#### Star Spring Washers

Axial spring elements for preloading of ball bearings.

Catalogue 20



Issued 03/2009

**RINGSPANN® CORPORATION**

10550 Anderson Place,  
Franklin Park, IL 60131

Telephone: 847-678-3581  
Fax: 847-678-3583

Web: [www.ringspanncorp.com](http://www.ringspanncorp.com)  
Email: [info@ringspanncorp.com](mailto:info@ringspanncorp.com)

